

Introduction



- **Extreme low power**
- **Long battery life**
- **Long distance range (3.5 Km LoS)**
- **Universal sensor input**
- **Real time transmission**

The Tekon Electronics In Head Wireless Universal Temperature Transmitter is specifically designed to meet the most rigorous requirements of operation in the industrial process environments. Due to its reduced dimension it may be installed in the DIN Form B sensor connection head in place of the traditional terminal block or current loop temperature transmitter.

The THW401 has an extreme low power operation mode that guaranties a long battery life. In its high power mode it can communicate over a long distance range (up to 3.5 Km Line of Sight). It accepts the most commonly used temperature sensors. The measured information (Sensor Temperature, Ambient Temperature, RF Signal Strength and Battery Status) is transmitted wireless to the receiver WGW410 and become available on the RS485 interface with Modbus protocol and in an analog current output.

The operating parameters like the sensor probe type and transmission interval can be easily configured using the OTA - Over The Air setup and configuration function. The Battery level and RF link quality may be verified on site during the installation process.

Key features

- Long distance range communication (up to 3.5 Km LoS)
- Extreme low power operation mode for long battery life
- Real time transmission of sensor temperature, ambient temperature, RF signal strength and battery status
- Wide range supply voltage
- *Over The Air* setup and configuration
- On site battery and RF signal strength verification
- Universal sensor input: Resistance thermometers (2, 3 or 4-wire system), Thermocouples, Resistance-based sensors and DC voltage sources.
- High measurement accuracy
- Sensor status monitoring
- Compact design for DIN Form B connection head mounting

Block diagram

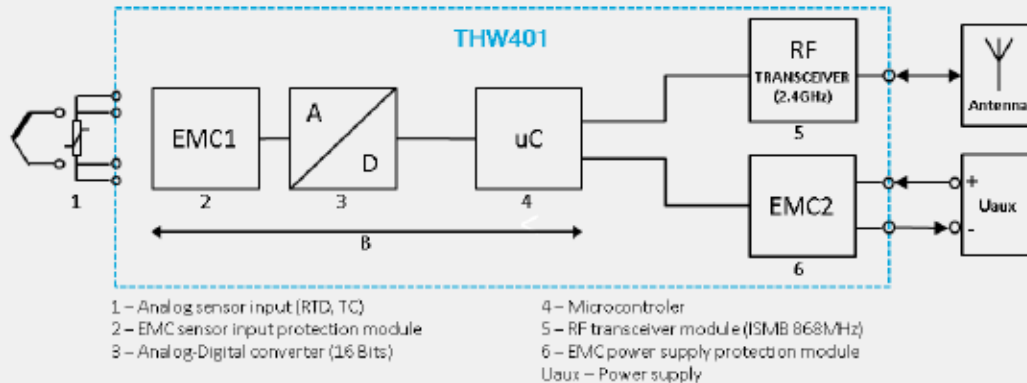

Technical specifications

Input Resistance thermometer (RTD)	
Measured variable	Temperature
Sensor type	Pt100, Pt500, Pt1000
Units	°C or °F
Connection	1 Resistance thermometer (RTD) in 2-wire, 3-wire or 4-wire system Resistance compensation in 2-wire systems available through software
Sensor current	<0.05 mA (50 µA)
Response time	<500 ms
Open-circuit monitoring	Always active (cannot be disabled)
Short-circuit monitoring	Always active (cannot be disabled)
Measuring range	Parameterizable (see table "Digital measuring errors")
Minimum measured span	50 °C (90 °F)
Characteristic curve	Temperature-linear

Input Thermocouples (TC)	
Measured variable	Temperature
Sensor type	E, J, K, N, R, S, T
Units	°C or °F
Connection	1 Thermocouple (TC)
Response time	<500 ms
Open-circuit monitoring	Always active (cannot be disabled)
Short-circuit monitoring	Not available
Cold junction compensation (CJC)	Integrated resistance thermometer
Measuring range	Configurable (see table "Digital measuring errors")
Minimum measured span	50 °C (90 °F)
Temperature-linear	Temperature-linear

Output RF transmission	
Transmission frequency	2.4GHz [2400; 2483] MHz
Transmission interval	Adjustable from 1s to 24h
Maximum output power	18 dBm
Sensitivity	-110 dBm
Open air range	3.5 Km LoS
Output signals	
Temp probe (RTD or TC)	Temperature °C (°F)
Internal Temp	Temperature °C (°F)
RSSI	Absolute value
Power supply level	Voltage V
Configurable parameters	Sensor type, Transmission interval

Measuring accuracy	
Digital measuring errors	See table "Digital measuring errors"
Reference conditions:	
Auxiliary power	9 V DC ± 1%
Ambient temperature	23 °C (73,4 °F)
Warming-up time	> 5 min
Error due to internal cold junction	< 0,5 °C (0,9 °F)
Influence of ambient temperature	
with resistance thermometers	0,06 °C (0,11 °F) / 10 °C (18 °F)
with thermocouples	0,6 °C (1,1 °F) / 10 °C (18 °F)

Digital measuring accuracy		
Resistance thermometer (RTD)		
Sensor	Range °C (°F)	Digital accuracy °C (°F)
Pt100	-200 to 850	0,1
	(-328 to 1562)	(0,18)
Pt500	-200 to 850	0,2
	(-328 to 1562)	(0,40)
Pt1000	-200 to 350	0,2
	(-328 to 662)	(0,40)

Digital measuring accuracy		
Thermocouples (TC)		
Sensor	Range °C (°F)	Digital accuracy °C (°F)
E	-200 to +1000 (-328 to +1832)	1
J	-210 to +1200 (-346 to +2192)	1
K	-230 to +1370 (-382 to +2498)	1
N	-200 to +1300 (-328 to +2372)	1
R	-50 to +1760 (-58 to +3200)	2
S	-50 to +1760 (-58 to +3200)	2
T	-200 to +400 (-328 to +752)	1

NOTE:
The digital accuracy is the accuracy after the analog/digital conversion including linearization and calculation of the measured value.

Power Supply	
Voltage Range	[5; 24] VDC
Power Consumption (Sleep)	< 0.2 mA
Battery Life	For a 9V battery, with 1200 mAh with a transmission interval of 2 minutes, the battery life is higher than 2 years

THW401

Universal Wireless Temperature Transmitter

Tekon

Temperature Measurement Solutions

Ambient conditions

Ambient temperature range	-20 to 80 °C (-4 a 176 °F)
Storage temperature range	-20 to 80 °C (-4 a 176 °F)
Relative humidity	≤ 95 %, without condensation

Certificates and approvals

EN 61326	Electrical equipment for measurement, control and laboratory use. EMC requirements.
IEC 61000-4-2	Electrostatic discharge immunity test
IEC 61000-4-3	Radiated, Radio-Frequency, Electromagnetic Field Immunity Test
IEC 61000-4-4	Electrical fast transient/burst immunity test
IEC 61000-4-5	Surge Immunity Test

Casing

Material	Nylon 66
Weight	Approx. 50 g
Dimensions	See "Dimensional drawings"
Cross-section of cables	2.5 mm ²
Protection type	IP40
Antenna connection	SMB connector

Factory settings

Sensor	Thermocouple K
Measuring range	0...100 °C (32 ... 212 °F)
Transmission interval	300 s
Node ID	1
Net ID	1

Dimensional drawings

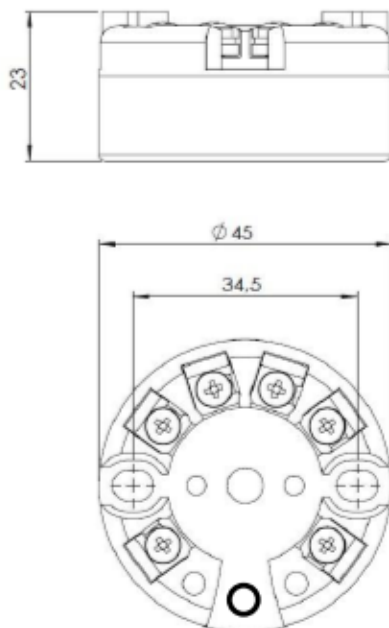

Installation diagram

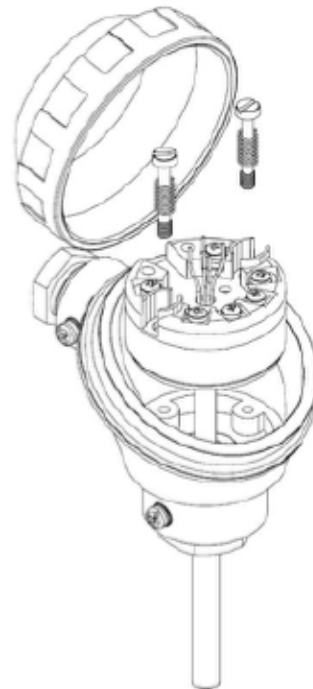

Electrical connections diagram

Resistance thermometer

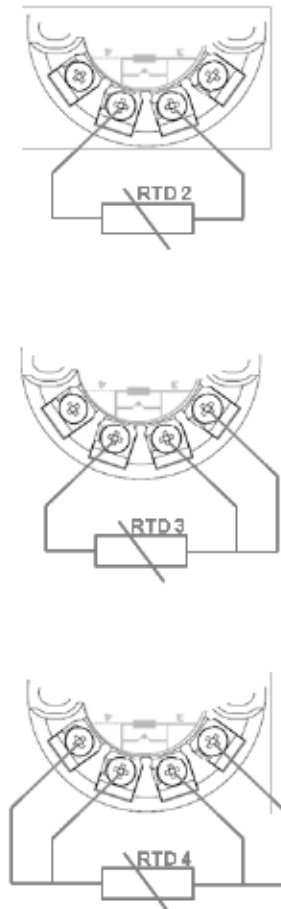

Termocouple

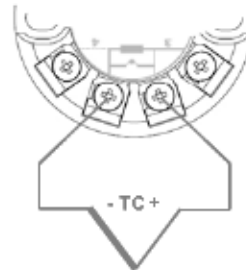

Power supply (Uaux)

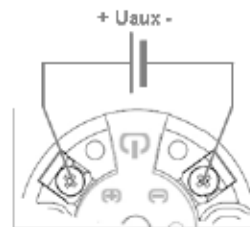

Installation procedure

1. Select the Node ID and Net ID. The Net ID must have the same value configured in the receiver WGW410. The Node ID must be unique for each Net ID.
2. Connect the temperature probe according to the electrical connections diagram.
3. Connect the power supply according to the electrical connections diagram.
4. Press the test button.
5. The THW401 will show the RSSI value in the status LEDs.
6. Next THW401 will show the value of the selected Node ID for confirmation.
7. Next THW401 will show the value of the selected Net ID for confirmation.

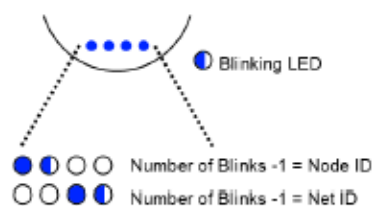

For further info on Installation Procedure, please check "STARTER KIT QUICK INSTALLATION GUIDE.PDF"

Battery Life time

The battery life time graph is a theoretical estimate. External factors as: Ambient temperatures, humidity, terrain topology, signal quality amongst others can influence the final outcome.

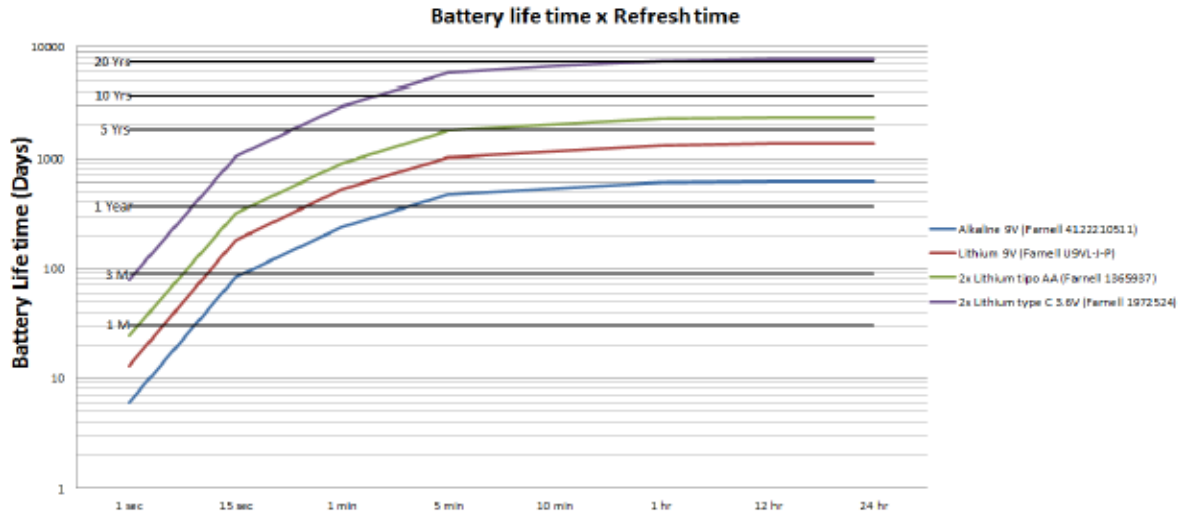

Selection and ordering data

Image	Partnumber	Partname
	PA123710 100	WIRELESS MODBUS GATEWAY WGW4 10 2.4GHZ
Related products		
	PA123720 100	TRANSM. TEMP. WIRELESS THW401 2.4GHZ

CONTROL Y REGULACIÓN TÉRMICA, S.L.
 Camí Vell de Russafa, 713
 46470 CATARROJA (VALENCIA)
 Telef. 96 3 74 72 71
 coreterm@coreterm.es
 www.coreterm.es



⁽¹⁾ Tekon is a registered trademark of Bresimar Automação S.A.